

4/2 and 4/3 directional valves, internally pilot-operated, externally pilot-operated

RE 24751-XE/04.16
Replaces: 09.13

Type H-4WEH ...XE

Sizes 10, 16, 25, 32
Component series 4X, 6X, 7X
Maximum operating pressure 350 bar
Maximum flow 1100 l/min

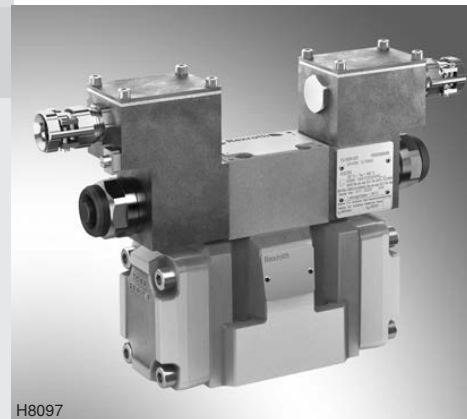

H8097

ATEX units – For potentially explosive atmospheres



Information on explosion protection:

- ▶ Area of application in accordance with the Explosion Protection Directive 2014/34/EU: **II 2G**
- ▶ Type of protection of the valve solenoids:
Ex eb mb IIC T4 Gb according to EN 60079-7 / EN 60079-18

Table of contents

Contents	Page
Features	1
Ordering code	2, 3
Symbols	4 ... 7
Function, section	8
Pilot oil supply	9
Technical data	9 ... 12
Electrical connection	13, 14
Characteristic curves	15
Performance limits	15 ... 19
Switching time adjustment, pressure reducing valve, preload valve	20
Dimensions	21 ... 25
Further information	26

Features

- For intended use in potentially explosive atmosphere
- For subplate mounting
- Porting pattern according to ISO 4401
- Spring centering, spring end position or hydraulic end position
- Wet-pin DC or AC solenoids
- Solenoid coil rotatable by 90°
- Manual override, optional
- Electrical connection as individual connection with cable gland
- Switching time adjustment, optional
- Preload valve in channel P of the main valve, optional

Ordering code

H	4	WEH		/	6E		XE
Up to 350 bar		= H					
4-way version		= 4					
Directional valve, electro-hydraulically actuated		= WEH					
Size							
NG10		= 10					
NG16		= 16					
NG25		= 25					
NG32		= 32					
Control spool return main valve							
By means of springs		= no code					
Hydraulically ¹⁾		= H					
For symbols, see page 4							
Component series 40 to 49 – NG10 (40 to 49: unchanged installation and connection dimensions)				= 4X			
Component series 60 to 69 – NG25 (4W.H 25.) and NG32 (60 to 69: unchanged installation and connection dimensions)				= 6X			
Component series 70 to 79 – NG16 (70 to 79: unchanged installation and connection dimensions)				= 7X			
Control spool return in the pilot control valve with 2 spool positions and 2 solenoids only possible with control spool C, D, K, Z and hydraulic control spool return in the main valve:							
Without spring return				= O			
Without spring return with detent				= OF			
Pilot control valve with wet-pin solenoids, high-power valve (RE 23178-XE)					= 6E		
Direct voltage 24 V					= G24		
AC voltage 230 V 50/60 Hz					= W230R		
For further ordering codes for other voltages, see page 14							
Without manual override					= no code		
With manual override (standard)					= N		
Explosion protection "Increased safety" For details see information on explosion protection, page 11						= XE	
Pilot oil supply external, pilot oil return external ²⁾						= no code	
Pilot oil supply internal, pilot oil return external ³⁾						= E	
Pilot oil supply internal, pilot oil return internal ³⁾						= ET	
Pilot oil supply external, pilot oil return internal ²⁾						= T	

Notice:

The manual override cannot be allocated a safety function and may only be used up to a tank pressure of 50 bar.

Explanation of the footnotes, see page 3

Symbols

2 spool positions

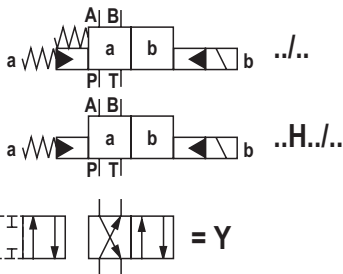
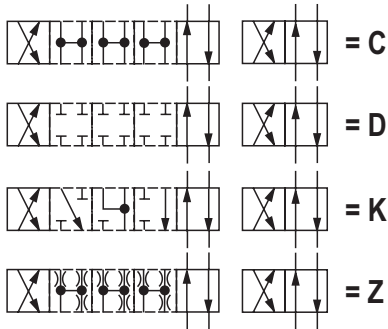
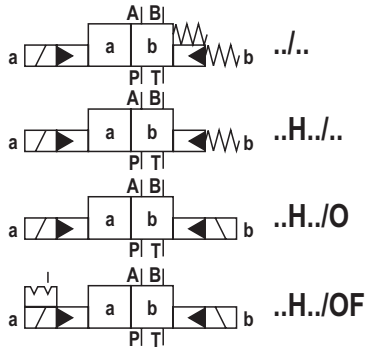

3 spool positions

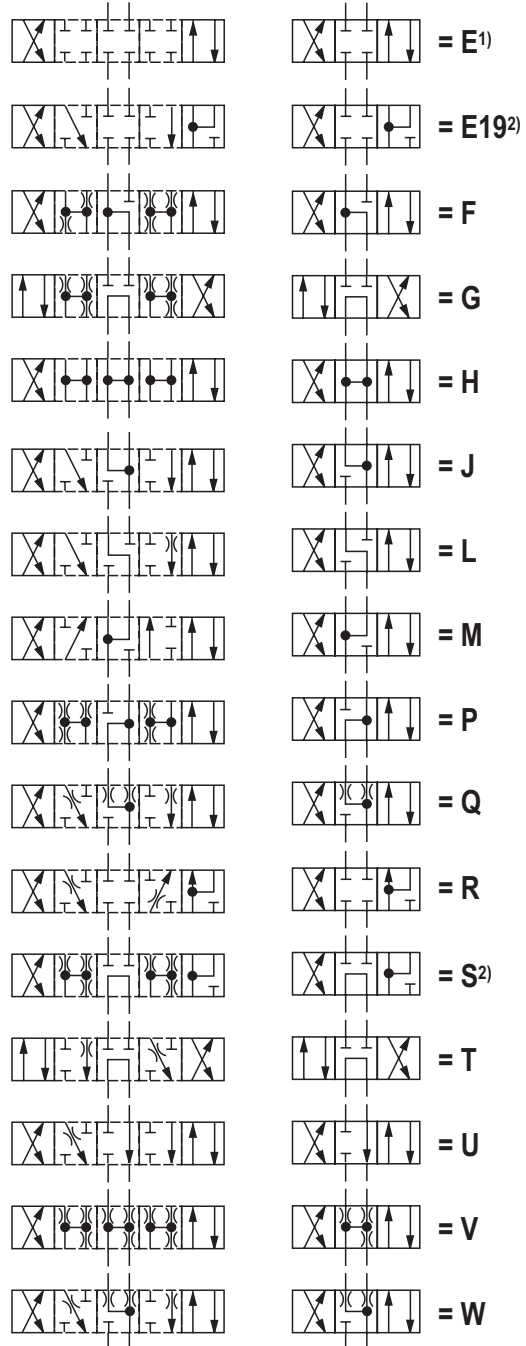
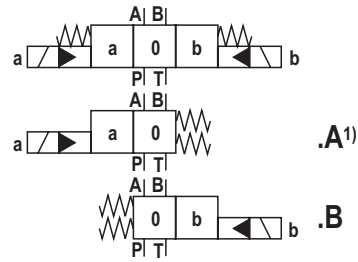

1) Example: Symbol E with switching position "a"
 Order example:
 H-4WEH 16 EA7X/6EG24N9XDETSZ2B10..V...

2) Only for NG16

Notices:

- Representation of the symbols according to DIN ISO 1219-1. Hydraulic interim positions are represented by dashes.
- Other symbols upon request

Symbols: Valve with 2 spool positions

	Valves with hydraulic end position			
	Type H-4WEH.../...	Type H-4WEH..H.../...	Type H-4WEH..H.../O...	Type H-4WEH..H.../OF...
X = external Y = external				
	X = internal Y = external			

Continuation, see next page

Symbols: Valve with 2 spool positions

Continuation from previous page

	Valves with spring end position		Valves with hydraulic end position	
	Type H-4WEH.../...ET...	Type H-4WEH..H.../...ET...	Type H-4WEH..H.../O...ET...	Type H-4WEH..H.../OF...ET...
X = internal Y = internal				
X = external Y = internal				

Symbols: Valves with 3 spool positions

Valves with spring-centered zero position

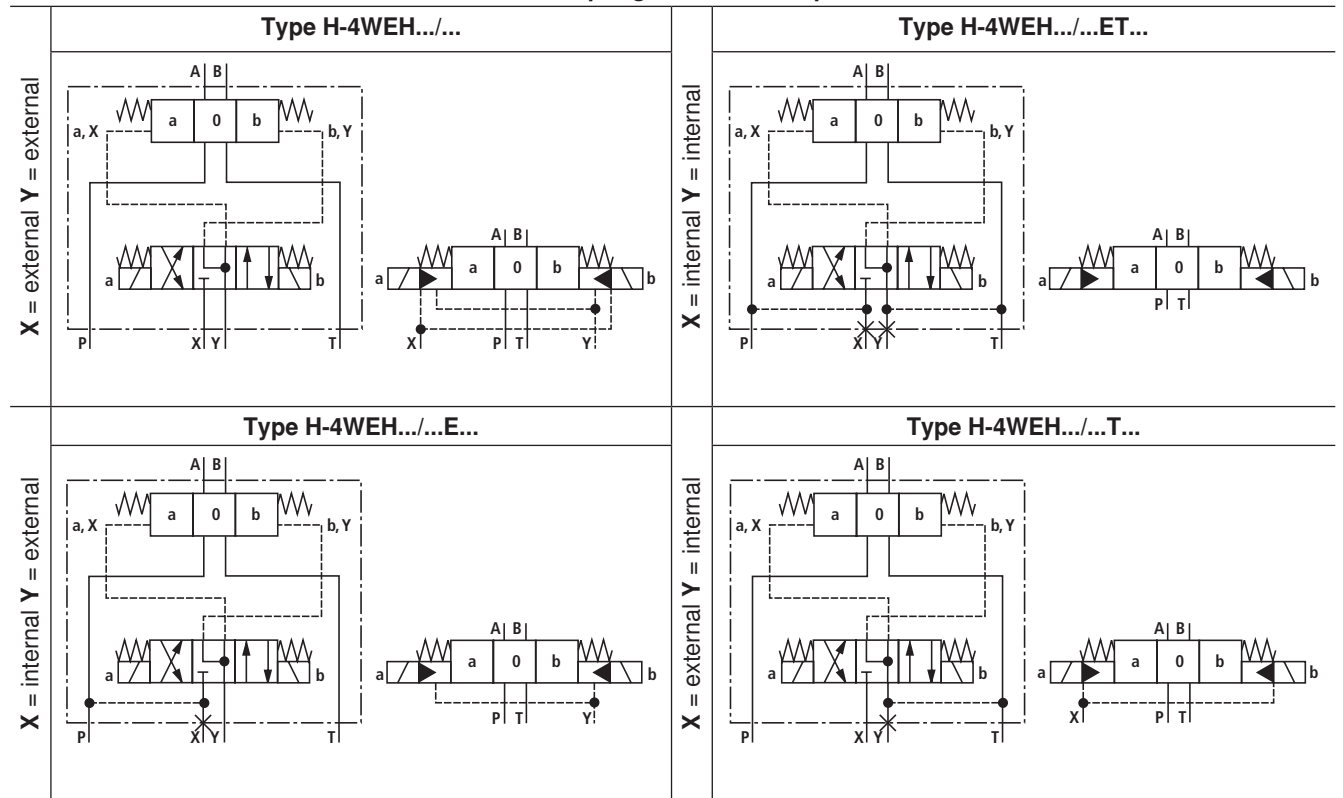

Function, section

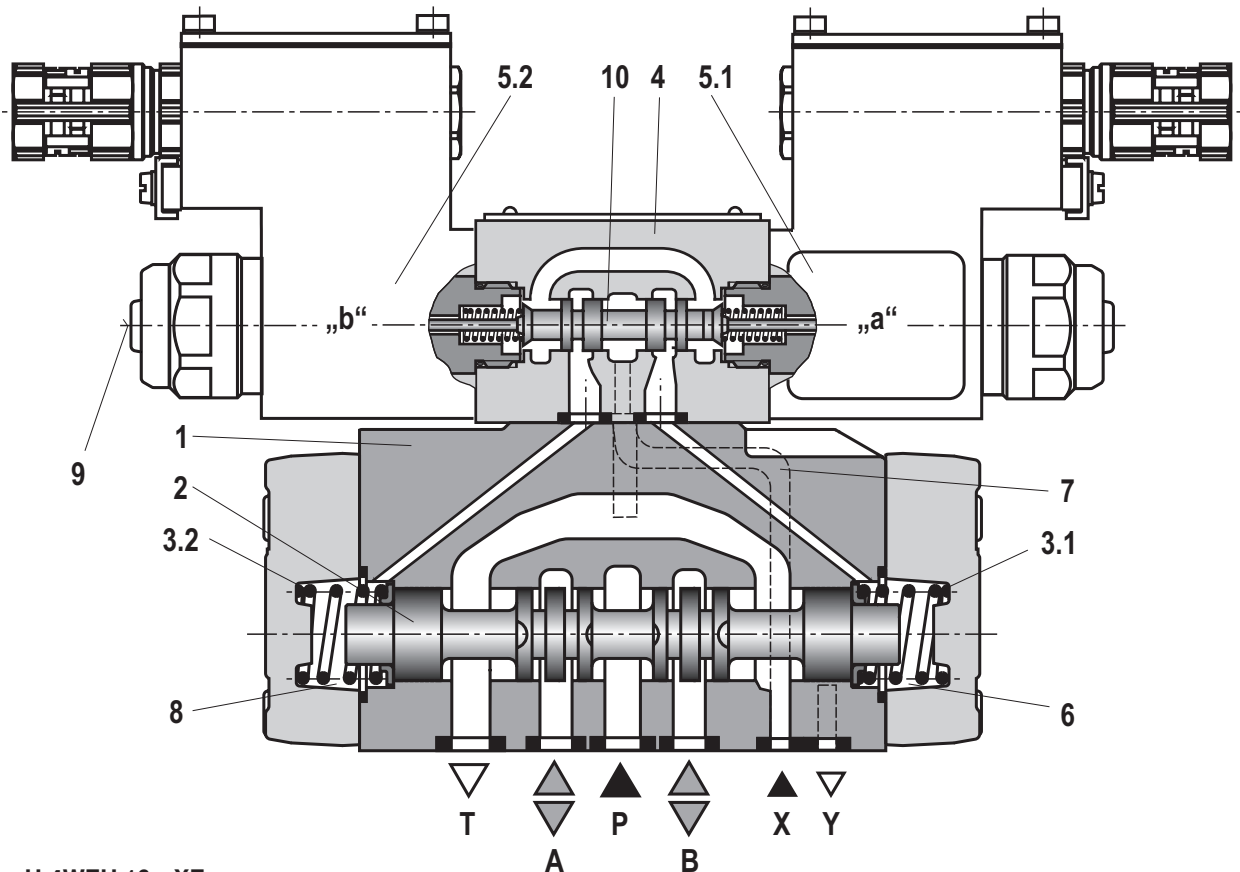

Type H-4WEH 16...XE...

Directional valves type H-4WEH...

The valve type H-4WEH is a directional spool valve with electro-hydraulic actuation. It controls the start, stop and direction of a flow.

The directional valve basically consists of the main valve with housing (1), the main control spool (2), one or two return springs (3.1) and (3.2), as well as the pilot control valve (4) with one or two solenoids "a" (5.1) and/or "b" (5.2).

The main control spool (2) in the main valve is held in the zero or initial position by the springs or by means of pressurization. In the initial position, the two spring chambers (6) and (8) are connected with the tank in a depressurized form via the pilot control valve (4). The pilot control valve is supplied with pilot oil via the control line (7). Supply can be effected internally or externally (externally via port X).

Upon actuation of the pilot control valve, e. g. solenoid "a", the pilot control spool (10) is moved to the left and thus, the spring chamber (8) is pressurized with pilot pressure. The spring chamber (6) remains depressurized.

The pilot pressure acts on the left side of the main control spool (2) and moves it against the spring (3.1). This connects ports P with B and A with T in the main valve.

When the solenoid is switched off, the pilot control spool returns into the initial position (except for impulse spool). The spring chamber (8) is unloaded to the tank.

The pilot oil from the spring chamber is displaced into channel Y via the pilot control valve.

The pilot oil supply and return can be effected internally or externally.

The manual override (9) allows control spool (10) to be moved without solenoid energization.

Notices:

The main control spool (2) is held in central position by the return springs (3.1) and (3.2) in spring chambers (6) and (8) without pilot pressure, even if the valve is positioned for example vertically.

Due to the design principle, internal leakage is inherent to the valves, which may increase over the life cycle.

Pilot oil supply

Type H-4WEH...

The pilot oil supply is effected **externally** via the X channel from a separate circuit.

The pilot oil return is effected **externally** via the Y channel into the tank.

Type H-4WEH...E...

The pilot oil supply is effected **internally** from the P channel of the main valve.

The pilot oil return is effected **externally** via the Y channel into the tank. In the subplate, port X is closed.

Type H-4WEH...ET...

The pilot oil supply is effected **internally** from the P channel of the main valve.

The pilot oil return is effected **internally** via the T channel into the tank. In the subplate, ports X and Y are closed.

Type H-4WEH...T...

The pilot oil supply is effected **externally** via the X channel from a separate circuit.

The pilot oil return is effected **internally** via the T channel into the tank. In the subplate, port Y is closed.

Throttle insert

Use of the throttle insert (2) is necessary if the pilot oil supply in the P channel of the pilot control valve (1) is to be limited.

The throttle insert (2) is inserted in channel P of the pilot control valve (1).

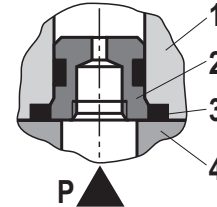

- 1 Pilot control valve
- 2 Throttle insert
- 3 Seal ring
- 4 Main valve

Technical data

general

Installation position	Any; horizontal with valves with hydraulic control spool return "H" and control spool C, D, K, Z or Y					
Ambient temperature range	°C	-20 ... +70 ¹⁾				
Storage temperature range	°C	+5 ... +40				
Maximum storage time	Years	1				
Sizes	NG	10	16	25	32	
Weight	Valve with one solenoid	kg	8.5	11	19	36.5
	Valve with two solenoids, spring-centered	kg	10.2	12.5	20.5	39
	Switching time adjustment	kg	0.8			
	Pressure reducing valve	kg	0.4			
Surface protection	Valve body	Pilot control valve	Galvanized			
		Main valve	Galvanized			
	Solenoid		Galvanized			
MTTFd value according to EN ISO 13849	Years	100				

¹⁾ Observe the "Special application conditions for safe application" on page 11.

Technical data

hydraulic		NG	10	16	25	32
Sizes						
Maximum operating pressure						
Ports P, A, B	bar	350				
Port T	with pilot oil return Y external	bar	250			
	with pilot oil return Y internal	bar	210			
Port Y	with pilot oil return external	bar	210			
Flow of the main valve	l/min	up to 160	up to 300	up to 650	up to 1100	
Maximum pilot pressure	bar	250 (with a higher pilot pressure, use of a pressure reducing valve is required)				
Minimum pilot pressure						
– with external or internal pilot oil supply X (control spool D, K, E, J, L, M, Q, R, U, W)						
3-spool position valve, spring-centered	bar	10	14	13	8.5	
2-spool position valve, spring end position	bar	10	14	13	10	
2-spool position valve, hydraulic end position	bar	7	14	8	5	
– with internal pilot oil supply X (control spools C, F, H, P, T, V, Z, S ²⁾)						
	bar	6.5 ³⁾	4.5 ⁴⁾	4.5 ⁴⁾	4.5 ⁴⁾	
Pilot volume for switching process						
3-spool position valve, spring-centered	cm ³	2.04	5.72	14.2	29.4	
2-spool position valve	cm ³	4.08	11.45	28.4	58.8	
Pilot volume for shortest switching time	l/min	approx. 35	approx. 35	approx. 35	approx. 45	
Hydraulic fluid		See table below				
Hydraulic fluid temperature range	°C	–20 ... +80 (NBR seals)				
		–15 ... +80 (FKM seals)				
Viscosity range	mm ² /s	2.8 ... 500				
Maximum admissible degree of contamination of the hydraulic fluid Cleanliness class according to ISO 4406 (c)		Class 20/18/15 ⁵⁾				
Maximum surface temperature	°C	See information on explosion protection on page 11				

Hydraulic fluid	Classification	Suitable sealing materials	Standards	Data sheet
Mineral oils	HL, HLP, HLPD	NBR, FKM	DIN 51524	90220
Bio-degradable	▶ Insoluble in water	HETG	ISO 15380	90221
		HEES		
	▶ Soluble in water	HEPG	ISO 15380	
Flame-resistant	▶ Containing water	HFC (Fuchs Hydrotherm 46M, Petrofer Ultra Safe 620)	ISO 12922	90223

Important information on hydraulic fluids:

- ▶ For further information and data on the use of other hydraulic fluids, please refer to the data sheets above or contact us!
- ▶ There may be limitations regarding the technical valve data (temperature, pressure range, life cycle, maintenance intervals, etc.)!
- ▶ Ignition temperature > 180 °C

▶ Flame-resistant – containing water:

- Maximum pressure differential per control edge 50 bar
- Pressure pre-loading at the tank port > 20% of the pressure differential, otherwise increased cavitation
- Life cycle as compared to operation with mineral oil HL, HLP 50 to 100%

Technical data

electric

Voltage type		Direct voltage	Alternating voltage
available voltages	V	24, 48, 96, 110	110, 230
Voltage tolerance (nominal voltage)	%	±10	
Admissible residual ripple	%	< 5	–
Duty cycle / operating mode according to VDE 0580		S1 (continuous operation)	
Switching time according to ISO 6403 ⁶⁾		See page 12	
Maximum switching frequency	1/h	15000	7200
Nominal power at an ambient temperature of 20 °C	W	17	
Maximum power with 1.1 x nominal voltage and an ambient temperature of 20 °C	W	20.6	
Protection class according to EN 60529		IP 66 (with correctly installed electrical connection)	

Notice:

Solenoids for AC voltage are DC solenoids with integrated rectifier

Information on explosion protection

Area of application in accordance with the explosion protection directive 2014/34/EU	II 2G
Type of protection valve	c (EN 13463-5)
Maximum surface temperature ⁷⁾	°C 135
Temperature class	T4
Type of protection valve solenoid according to EN 60079-7 / EN 60079-18	Ex eb mb IIC T4 Gb
Type examination certificate solenoid	KEMA 02ATEX2240 X
"IECEX Certificate of Conformity" solenoid	IECEX DEK 12.0068X
Ambient temperature range	°C –20 ... +70 ¹⁾
Special application conditions for safe application	<ul style="list-style-type: none"> – In case of valves with two solenoids, maximally one of the solenoids may be energized at a time. – Simultaneous power supply of several valves in bank assembly is possible if the ambient temperature does not exceed 60 °C. – In case of bank assembly, if only one of the solenoids is energized at a time, and during individual operation, the maximum ambient temperature may not exceed 70 °C. – The maximum temperature of the surface of the valve jacket is 120 °C. This has to be considered when selecting the connection cable and/or contact of the connection cable with the surface of the jacket is to be prevented.

¹⁾ Observe the "Special application conditions for safe application" on page 11.

²⁾ Symbol S only for NG16

³⁾ For symbols C, F, G, H, P, T, V, Z, an internal pilot oil supply without preload valve is only possible if the flow from P → T in the central position (for 3-spool position valve) or while crossing the central position (for 2-spool position valve) is so large that the pressure differential of P → T reaches a value of at least 6.5 bar.

⁴⁾ For symbols C, F, G, H, P, T, V, Z, S ¹⁾ – by means of a preload valve (not Size 10) or a correspondingly high flow

⁵⁾ The cleanliness classes specified for the components must be adhered to in hydraulic systems. Effective filtration prevents faults and at the same time increases the life cycle of the components.

For the selection of the filters, see www.boschrexroth.com/filter.

⁶⁾ The switching times were determined at a hydraulic fluid temperature of 40 °C and a viscosity of 46 cSt. Deviating hydraulic fluid temperatures can result in different switching times. Switching times change dependent on operating time and application conditions.

⁷⁾ Surface temperature > 50 °C, provide contact protection.

Technical data

Switching times (= Contacting at the pilot control valve until start of opening of the control edge in the main valve and change in the control spool stroke by 95%)

Pilot pressure		bar	70	250	Spring
			ON		OFF
NG10	without throttle insert	ms	50 ... 70	50 ... 70	30 ... 40
	with throttle insert	ms	70 ... 100	60 ... 80	30 ... 40
NG16	without throttle insert	ms	60 ... 90	50 ... 70	60 ... 90
	with throttle insert	ms	120 ... 140	90 ... 110	60 ... 90
NG25	without throttle insert	ms	80 ... 110	60 ... 80	110 ... 140
	with throttle insert	ms	210 ... 260	130 ... 160	110 ... 140
NG32	without throttle insert	ms	90 ... 140	80 ... 110	150 ... 170
	with throttle insert	ms	430 ... 570	240 ... 360	150 ... 170

Notices:

- The switching times are measured according to ISO 6403 with HLP46, $t_{oil} = 40 \text{ °C} \pm 5 \text{ °C}$.
With different oil temperatures, variations are possible.
- The switching times increase by approx. 30 ms if the pressure reducing valve "D3" is used.
- The switching times have been determined under ideal conditions and may differ in the system, depending on the application conditions.

Free flow cross-sections in zero position with control spools Q, V and W

Control spool	Position	mm ²	13	32	78	83	78
Control spool Q	A – T, B – T	mm ²	13	32	78	83	78
	A – T, B – T	mm ²	13	32	73	83	73
Control spool V	P – A, P – B	mm ²	13	32	84	83	84
	A – T, B – T	mm ²	2.4	6	10	14	20

Electrical connection

The type-examination tested valve solenoid of the valve is equipped with a terminal box and a type-tested cable gland.

The connection is polarity-independent.

Solenoids to be connected to AC voltage are equipped with an integrated rectifier.

Notice

When establishing the electrical connection, the protective earthing conductor (PE \perp) has to be connected properly.

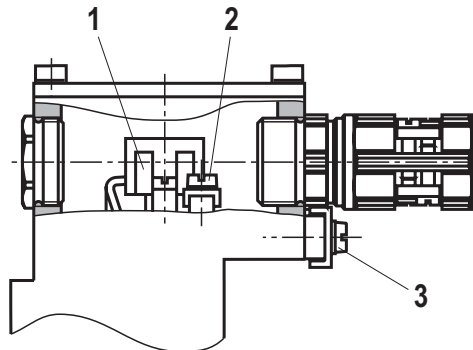

Properties of the connection terminals

Position	Function	Connectable line cross-section
1	Operating voltage connection	Single-wire 0.75 ... 2.5 mm ² Finely stranded 0.75 ... 1.5 mm ²
2	Connection for protective earthing conductor	Single-wire max. 2.5 mm ² Finely stranded max. 1.5 mm ²
3	Connection for potential equalization conductor	Single-wire 4 ... 6 mm ² Finely stranded 4 mm ²

Cable gland

Type approval	II 2G Ex e IIC Gb
Threaded connection	M20 x 1.5
Protection class according to EN 60529	IP 66 (with correctly installed electrical connection)
Line diameter	mm 7 ... 10.5
Sealing	Outer sheath sealing

Connection line

Line type	Non-armored cables and lines (outer sheath sealing)
Temperature range	°C -30 ... > +110

Electrical connection

Circuit diagrams

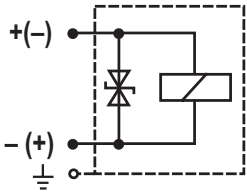
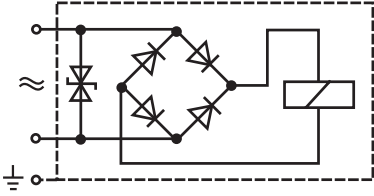
Direct voltage, polarity-independent	Alternating voltage
	

Over-current fuse and switch-off voltage peak

Notice:

A fuse which corresponds to the rated current according to DIN 41571 and EN / IEC 60127 has to be connected upstream of every valve solenoid (max. $3 \times I_{rated}$).

The shut-off threshold of the fuse has to match the prospective short-circuit current of the supply source.

The prospective short-circuit current of the supply source may amount to a maximum of 1500 A.

This fuse may only be installed outside the potentially explosive atmosphere or must be of an explosion-proof design.

When inductivities are switched off, voltage peaks result which may cause faults in the connected control electronics.

The voltage peak must be damped by a suitable external circuitry. We recommend a circuitry with a suppressor diode with a limitation voltage of approx. 50 V.

Voltage data in the valve type code	Nominal voltage valve solenoid	Rated current valve solenoid	Rated current for external miniature fuse: medium time-lag (M) according to DIN 41571 and EN/IEC 60127	Rated voltage for external miniature fuse: medium time-lag (M) according to DIN 41571 and EN/IEC 60127	Maximum voltage value upon switch-off	Interference protection circuit
G24	24 V DC	0.708 A DC	800 mA	250 V	-90 V	Suppressor diode bi-directional
G48	48 V DC	0.354 A DC	400 mA	250 V	-200 V	
G96	96 V DC	0.177 A DC	200 mA	250 V	-370 V	
G110	110 V DC	0.155 A DC	200 mA	250 V	-390 V	
W110R	110 V AC	0.163 A AC	200 mA	250 V	-3 V	Bridge rectifier and suppressor diode
W230R	230 V AC	0.078 A AC	80 mA	250 V	-3 V	

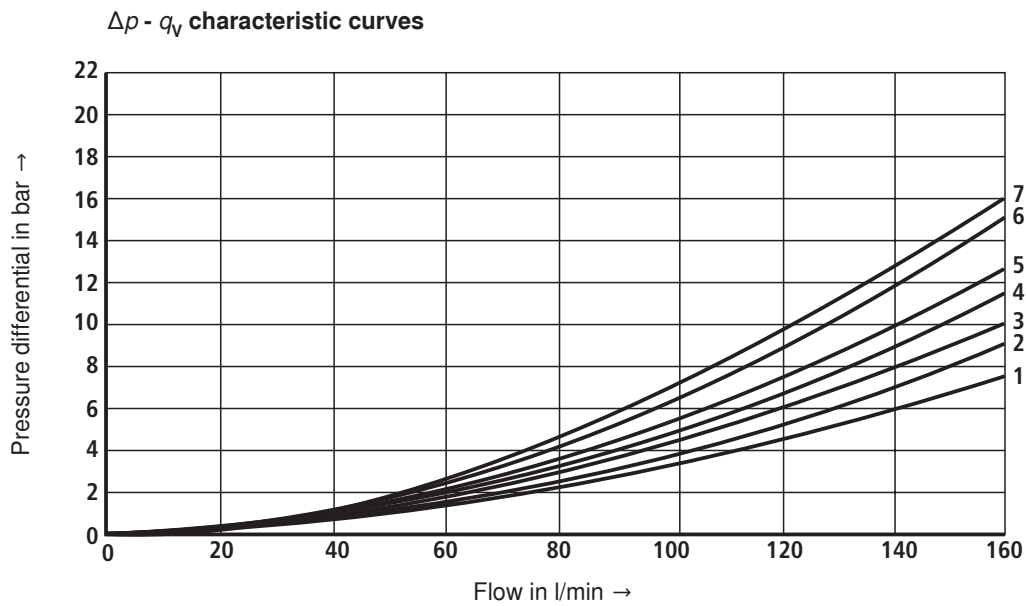
Characteristic curves: Type H-4WEH 10... (measured with HLP46, $\vartheta_{oil} = 40\text{ °C} \pm 5\text{ °C}$)

Symbol	Spool position				Symbol	Zero position		
	P – A	P – B	A – T	B – T		A – T	B – T	P – T
E, Y, D	2	2	4	5				
F	1	4	1	4	F	3	–	6
G, T	4	2	2	6	G, T	–	–	7
H, C	4	4	1	4	H	1	3	5
J, K	1	2	1	3				
L	2	3	1	4	L	3	–	–
M	4	4	3	4				
P	4	1	3	4	P	–	7	5
Q, V, W, Z	2	2	3	5				
R	2	2	3	–				
U	3	3	3	4	U	–	4	–

Performance limits: Type H-4WEH 10... (measured with HLP46, $\vartheta_{oil} = 40\text{ °C} \pm 5\text{ °C}$)

2- and 3-spool position valves
maximum flow q_v in l/min

Important notices see page 19.

Symbol	Operating pressure p_{max} in bar		
	200	250	315
E, J, L, M, Q, R, U, V, W, C, D, K, Z, Y	160	160	160
H	160	150	120
G, T	160	160	140
F, P	160	140	120

Characteristic curves: Type H-4WEH 16... (measured with HLP46, $\vartheta_{oil} = 40 \text{ }^\circ\text{C} \pm 5 \text{ }^\circ\text{C}$)

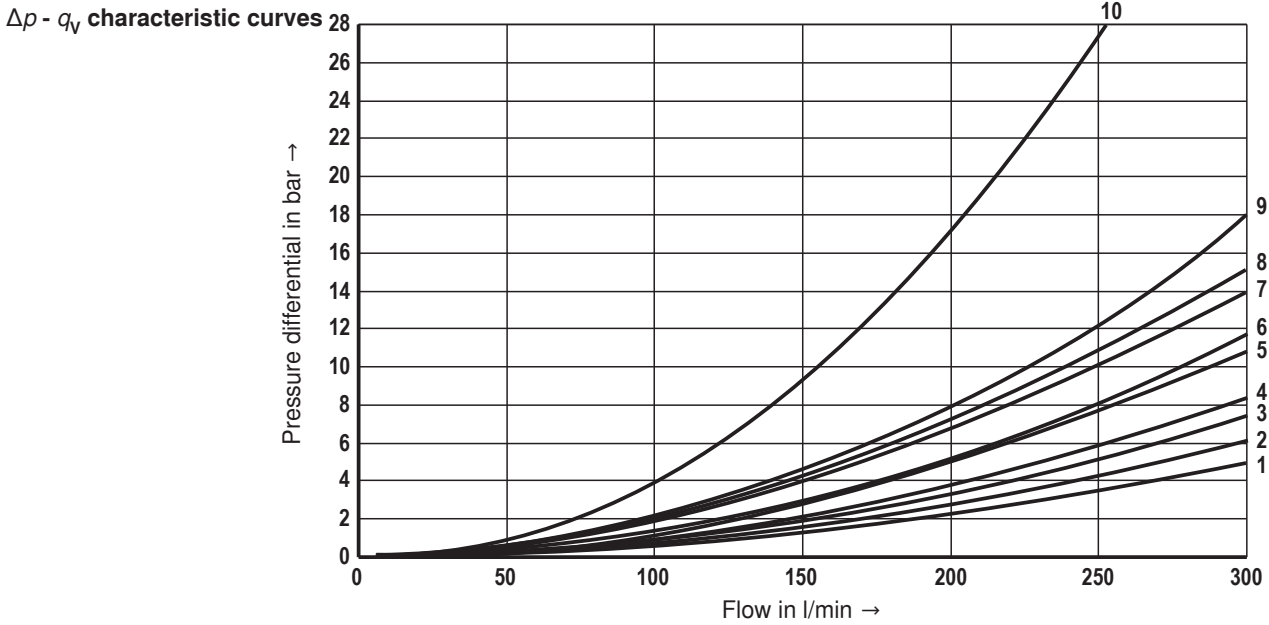

Symbol	Spool position				
	P - A	P - B	A - T	B - T	P - T
E, Y, D	1	1	3	4	-
E19	-	6	8	7	-
F	1	1	5	4	-
G, T	4	1	5	5	9
H, C, Q, V, Z	1	1	5	6	-
J, K, L	1	1	5	6	-

Symbol	Spool position				
	P - A	P - B	A - T	B - T	P - T
M, W	1	1	3	4	-
R	1	1	3	-	-
U	2	2	3	5	-
S	3	3	3	-	10

Performance limits: Type H-4WEH 16... (measured with HLP46, $\vartheta_{oil} = 40 \text{ }^\circ\text{C} \pm 5 \text{ }^\circ\text{C}$)

2-spool position valve
maximum flows q_v in l/min

Symbol	Operating pressure p_{max} in bar				
	70	140	210	280	350
X external, spring end position in the main valve (with $p_{St min} = 12 \text{ bar}$)					
C, D, K, Y, Z	300	300	300	300	300
X external, spring end position in the main valve ¹⁾					
C	300	300	300	300	300
D, Y	300	270	260	250	230
K	300	250	240	230	210
Z	300	260	190	180	160
X external, hydraulic end position in the main valve					
HC, HD, HK, HZ, HY	300	300	300	300	300

3-spool position valve
maximum flows q_v in l/min

Control spool	Operating pressure p_{max} in bar				
	70	140	210	280	350
X external, spring centering in the main valve					
E, E19, H, J, L, M, Q, U, W, R	300	300	300	300	300
F, P	300	250	180	170	150
G, T	300	300	240	210	190
S	300	300	300	250	220
V	300	250	210	200	180

¹⁾ If the specified flow values are exceeded, the function of the return spring is no longer guaranteed if the pilot pressure fails!

- With control spools V, Z and HZ, the preload valve is **not** required for flows > 180 l/min.

Important notices see page 19.

Characteristic curves: Type H-4WEH 25... (measured with HLP46, $\vartheta_{oil} = 40 \text{ }^\circ\text{C} \pm 5 \text{ }^\circ\text{C}$)

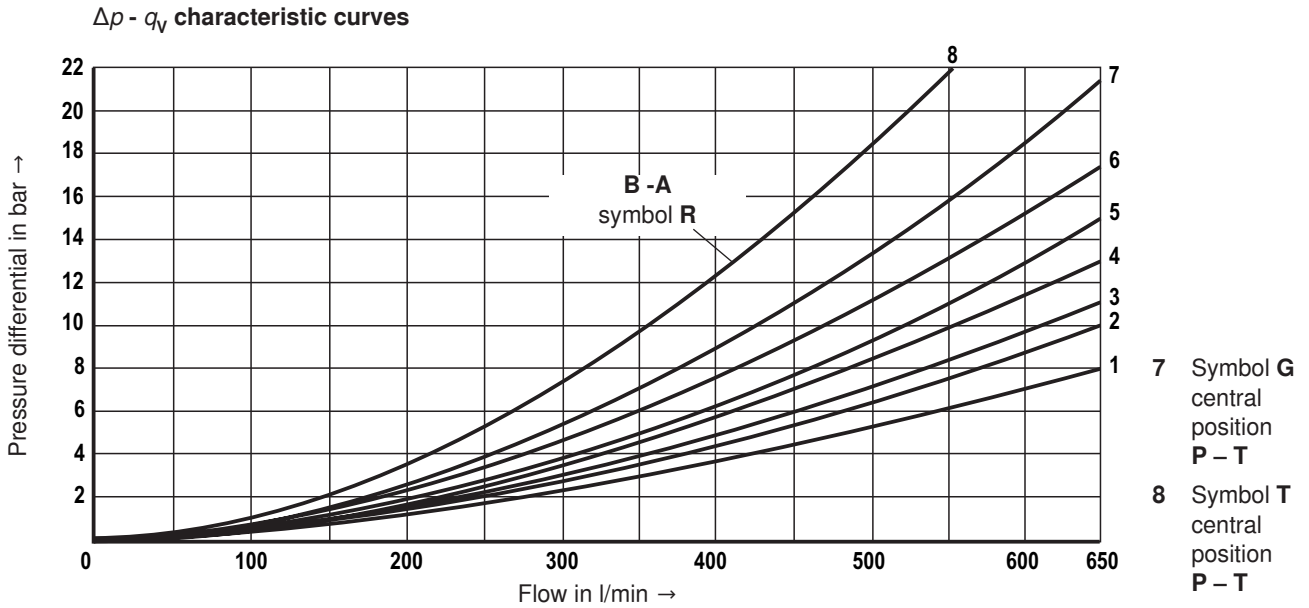

Characteristic curve selection

Symbol	Spool position			
	P - A	P - B	A - T	B - T
E	1	1	1	3
F	1	4	3	3
G	3	1	2	4
H	4	4	3	4
J, Q	2	2	3	5

Symbol	Spool position			
	P - A	P - B	A - T	B - T
L	2	2	3	3
M	4	4	1	4
P	4	1	1	5
R	2	1	1	-

Symbol	Spool position			
	P - A	P - B	A - T	B - T
U	4	1	1	6
V	2	4	3	6
W	1	1	1	3
T	3	1	2	4

Performance limits: Type H-4WEH 25... (measured with HLP46, $\vartheta_{oil} = 40 \text{ }^\circ\text{C} \pm 5 \text{ }^\circ\text{C}$)

2-spool position valve

maximum flows q_v in l/min

Symbol	Operating pressure p_{max} in bar				
	70	140	210	280	350
X external, spring end position in the main valve (with $p_{St min} = 13 \text{ bar}$)					
C, D, K, Y, Z	700	700	700	700	650
X external, spring end position in the main valve ¹⁾					
C	700	700	700	700	650
D, Y	700	650	400	350	300
K	700	650	420	370	320
Z	700	700	650	480	400
X external, hydraulic end position in the main valve					
HC, HD, HK, HZ, HY	700	700	700	700	700
HC../O.. HD../O.. HK../O.. HZ../O..	700	700	700	700	700
HC../OF.. HD../OF.. HK../OF.. HZ../OF..	700	700	700	700	700

3-spool position valve

maximum flows q_v in l/min

Symbol	Operating pressure p_{max} in bar				
	70	140	210	280	350
X external, spring centering in the main valve					
E, L, M, Q, U, W,	700	700	700	700	650
G, T	400	400	400	400	400
F	650	550	430	330	300
H	700	650	550	400	360
J	700	700	650	600	520
P	650	550	430	330	300
V	650	550	400	350	310
R	700	700	700	650	580

¹⁾ If the specified flow values are exceeded, the function of the return spring is no longer guaranteed if the pilot pressure fails!

Important notices see page 19.

Characteristic curves: Type H-4WEH 32... (measured with HLP46, $\vartheta_{oil} = 40 \text{ }^\circ\text{C} \pm 5 \text{ }^\circ\text{C}$)

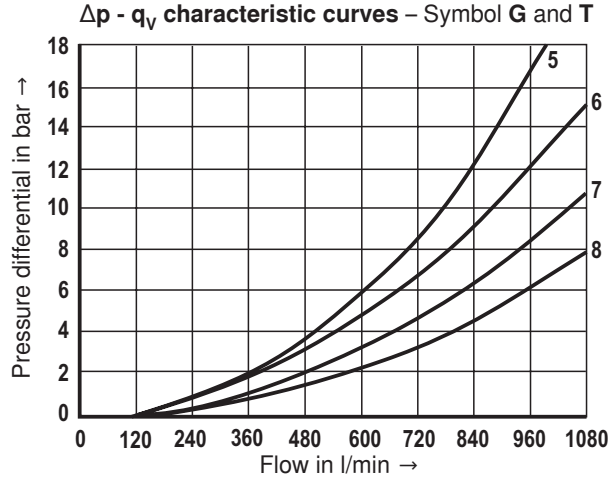
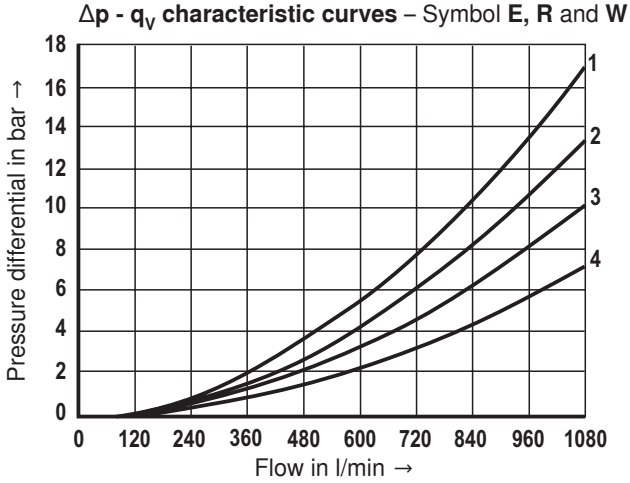

Symbol	Spool position				
	P – A	P – B	A – T	B – T	B – A
E	4	4	3	2	–
R	4	4	3	–	1
W	4	4	3	2	–

Symbol	Spool position				
	P – A	P – B	A – T	B – T	P – T
G	7	8	7	5	6
T	7	8	7	5	6

Performance limits: Type H-4WEH 32... (measured with HLP46, $\vartheta_{oil} = 40 \text{ }^\circ\text{C} \pm 5 \text{ }^\circ\text{C}$)

2-spool position valve
maximum flows q_v in l/min

Symbol	Operating pressure p_{max} in bar				
	70	140	210	280	350
X external, spring end position in the main valve (with $p_{St min} = 10 \text{ bar}$)					
C, D, K, Y, Z	1100	1040	860	750	680
X external, spring end position in the main valve ¹⁾					
C	1100	1040	860	800	700
D, Y	1100	1040	540	480	420
K	1100	1040	860	500	450
Z	1100	1040	860	700	650
X external, hydraulic end position in the main valve					
HC, HD, HK, HZ, HY	1100	1040	860	750	680

3-spool position valve
maximum flows q_v in l/min

Symbol	Operating pressure p_{max} in bar				
	70	140	210	280	350
X external, spring centering in the main valve					
E, J, L, M, Q, U, W, R	1100	1040	860	750	680
G, T, H, F, P	900	900	800	650	450
V	1100	1000	680	500	450

¹⁾ If the specified flow values are exceeded, the function of the return spring is no longer guaranteed if the pilot pressure fails!

Important notices see page 19.

Performance limits: important notices

Notice (applies to all sizes):

The specified switching power limits are valid for use with two directions of flow (e. g. from P to A and simultaneous return flow from B to T at a ratio of 1:1).

Due to the flow forces acting within the valves, the admissible switching power limit may be considerably lower with only one direction of flow (e. g. from P to A while port B

is blocked, with flow in the same or different directions)!
In such cases, please consult us!

The switching power limit was established while the solenoids were at operating temperature, at 10% undervoltage and without tank preloading.

NG16	<ul style="list-style-type: none"> - With pilot oil supply X internal, a preload valve has to be used for flows < 160 l/min due to the negative overlap of symbols V, C, Z and HC, HZ. - With pilot oil supply X internal, sufficient flow has to be ensured due to the negative overlap of symbols F, G, H, P, S and T (for the determination of the required flow, see "Preload valve" characteristic curves (page 20). If the required flow is not reached, a preload valve has to be used (see page 10).
NG25	<ul style="list-style-type: none"> - With pilot oil supply X internal, a preload valve has to be used for flows < 180 l/min due to the negative overlap of the symbols Z, HZ and V. - With pilot oil supply X internal, sufficient flow has to be ensured due to the negative overlap of symbols C, HC, F, G, H, P, and T (for the determination of the required flow, see "Preload valve" characteristic curves (page 20). If the required flow is not reached, a preload valve has to be used (see page 10).
NG32	<ul style="list-style-type: none"> - With pilot oil supply X internal, a preload valve has to be used for flows < 180 l/min due to the negative overlap of the symbols Z, HZ and V. - With pilot oil supply X internal, sufficient flow has to be ensured due to the negative overlap of symbols C, HC, F, G, H, P, and T (for the determination of the required flow, see "Preload valve" characteristic curves (page 20). If the required flow is not reached, a preload valve has to be used (see page 10).

Switching time adjustment, pressure reducing valve, preload valve

Switching time adjustment "S/S2"

The switching time of the main valve (1) is influenced by using a twin throttle check valve (2), type Z2FS 6.

Symbol (3) shows the switching time adjustment "S" (supply control), symbol (4) shows the switching time adjustment "S2" (discharge control)

Type H-4WEH 10 ..4X/...S or S2

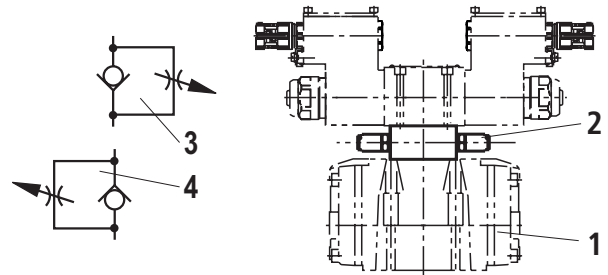

Pressure reducing valve "D3"

With the design internal pilot oil supply (ET or E) or external pilot oil supply and a pilot pressure of more than 250 bar, the valve must be ordered with a pressure reducing valve (5), type ZDR6PO, **and** a throttle insert "B10".

Ordering code: "B10..D3"

Type H-4WEH 10 ..4X/.../..D3

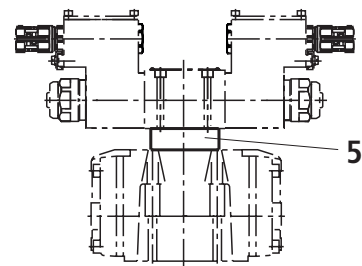

Preload valve "P4,5" (not for NG10)

In case of valves with depressurized circulation and internal pilot oil supply, a preload valve is required in channel P of the main valve in order to build up the minimum pilot pressure.

Ordering code: "P4,5"

The pressure differential of the preload valve is to be added to the pressure differential of the main valve (see characteristic curves) to result in one total value.

The cracking pressure amounts to approx. 4.5 bar.

$\Delta p - q_v$ characteristic curve

(measured with HLP46, $\vartheta_{Oil} = 40 \text{ }^\circ\text{C} \pm 5 \text{ }^\circ\text{C}$)

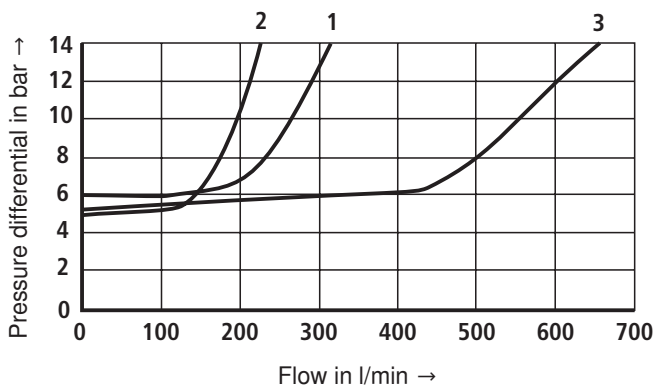

1 = NG16 2 = NG25 3 = NG32

Dimensions: Type H-4WEH 10... (dimensions in mm)

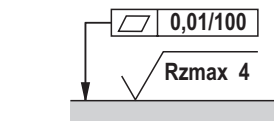
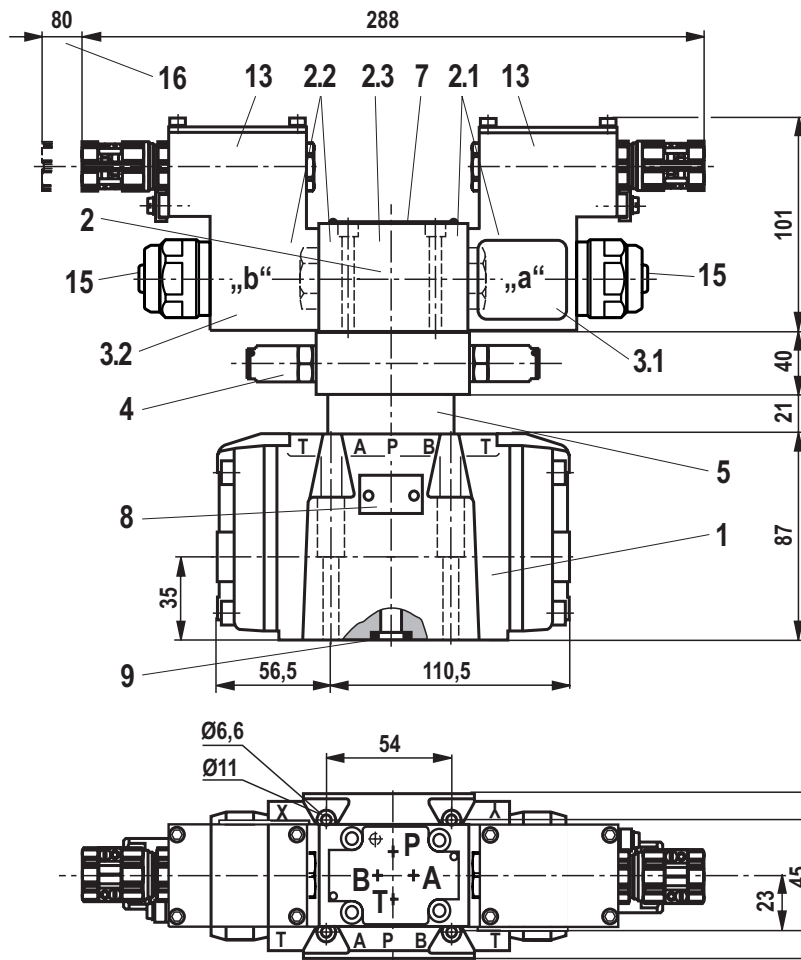

Required surface quality of the valve contact surface

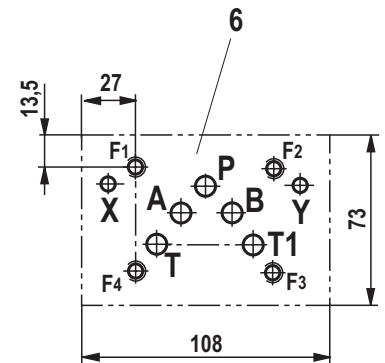

Subplates (separate order) with porting pattern according to ISO 4401-05-05-0-05, see data sheet 45100.

Notice:

Subplates are no components in the sense of directive 2014/34/EU and can be used after the manufacturer of the overall system has conducted an assessment of the risk of ignition. The "G...J3" versions are free from aluminum and/or magnesium and galvanized.

Valve mounting screws (separate order)

For reasons of stability, exclusively use the following valve mounting screws:

4 hexagon socket head cap screws

ISO 4762 - M6x45-10.9-fIZn-240h-L

(friction coefficient $\mu_{total} = 0.09$ to 0.14)

Item explanations see page 25.

Dimensions: Type H-4WEH 16... (dimensions in mm)

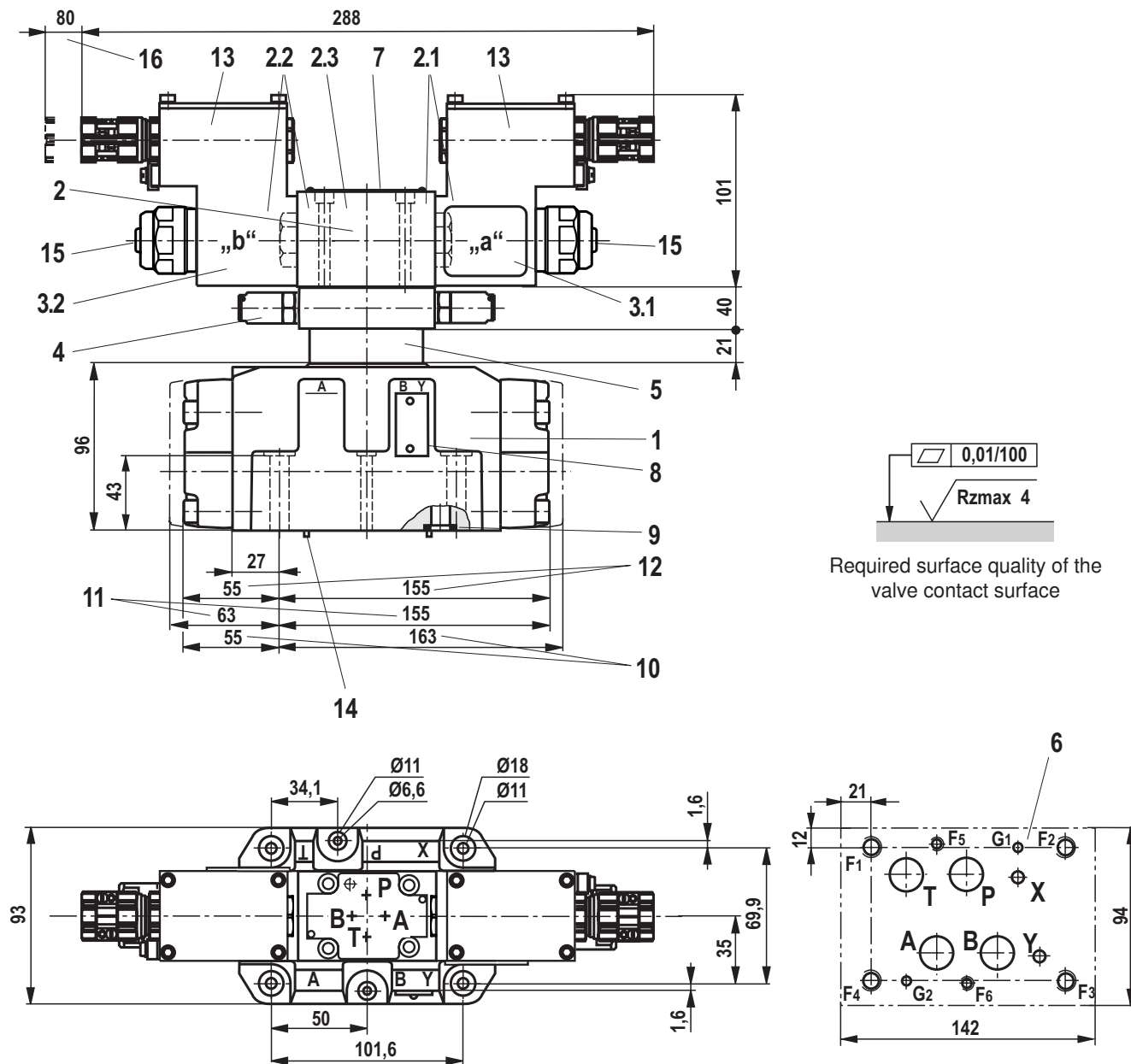

Subplates (separate order) with porting pattern according to ISO 4401-07-07-0-05, see data sheet 45100.

Notice:

Subplates are no components in the sense of directive 2014/34/EU and can be used after the manufacturer of the overall system has conducted an assessment of the risk of ignition. The "G...J3" versions are free from aluminum and/or magnesium and galvanized.

Valve mounting screws (separate order)

For reasons of stability, exclusively use the following valve mounting screws:

4 hexagon socket head cap screws
ISO 4762-M10x60-10.9-flZn-240h-L
 (friction coefficient total: 0.09-0.14 according to VDA 235-101)

2 hexagon socket head cap screws
ISO 4762-M6x60-10.9-flZn-240h-L
 (friction coefficient $\mu_{total} = 0.09$ to 0.14)

Item explanations see page 25.

Dimensions: Type H-4WEH 25... (dimensions in mm)

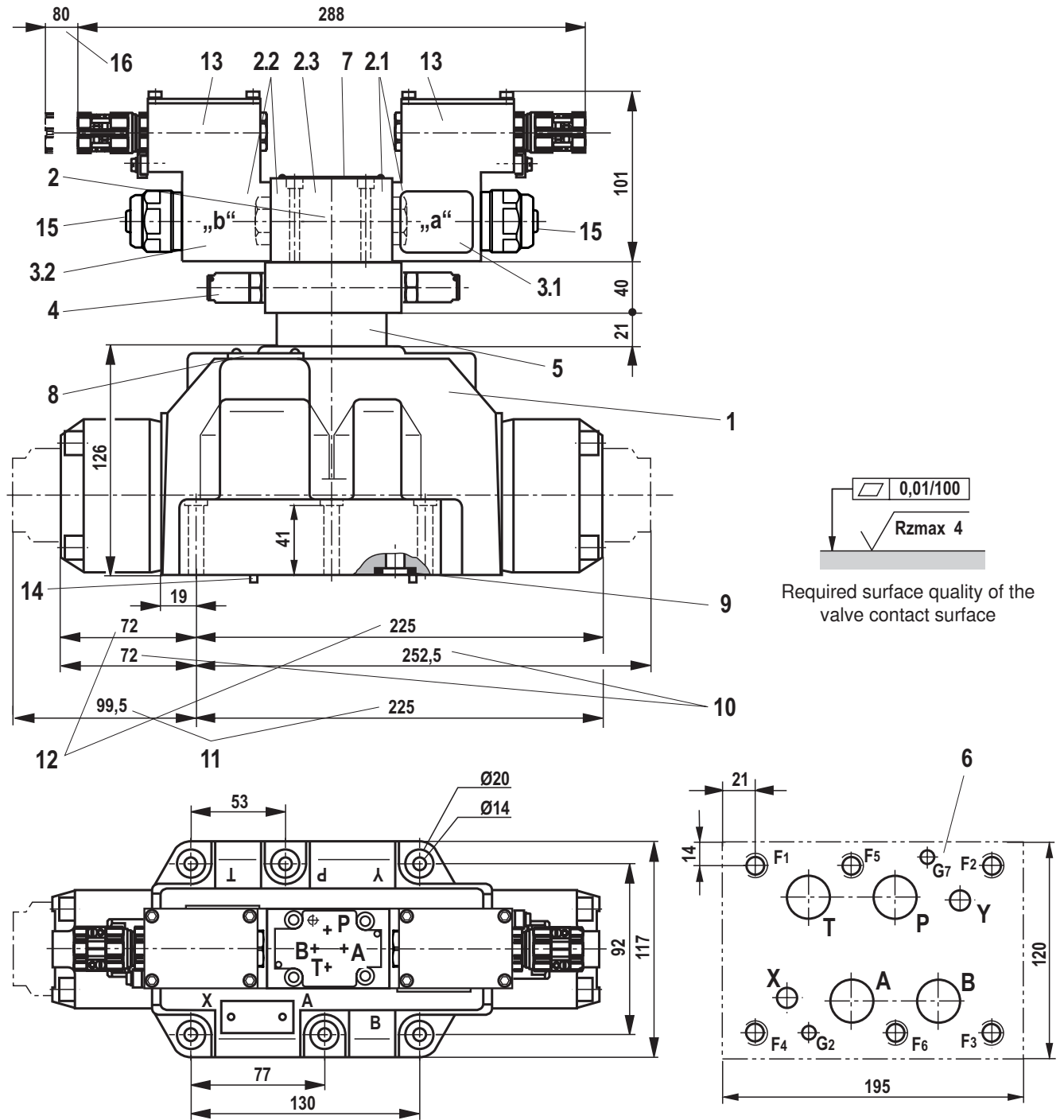

Subplates (separate order) with porting pattern according to ISO 4401-08-08-0-05, see data sheet 45100.

Notice:

Subplates are no components in the sense of directive 2014/34/EU and can be used after the manufacturer of the overall system has conducted an assessment of the risk of ignition. The "G...J3" versions are free from aluminum and/or magnesium and galvanized.

Valve mounting screws (separate order)

For reasons of stability, exclusively use the following valve mounting screws:

6 hexagon socket head cap screws
ISO 4762-M12x60-10.9-fIZn-240h-L
 (friction coefficient $\mu_{total} = 0.09$ to 0.14)

Item explanations see page 25.

Dimensions: Type H-4WEH 32... (dimensions in mm)

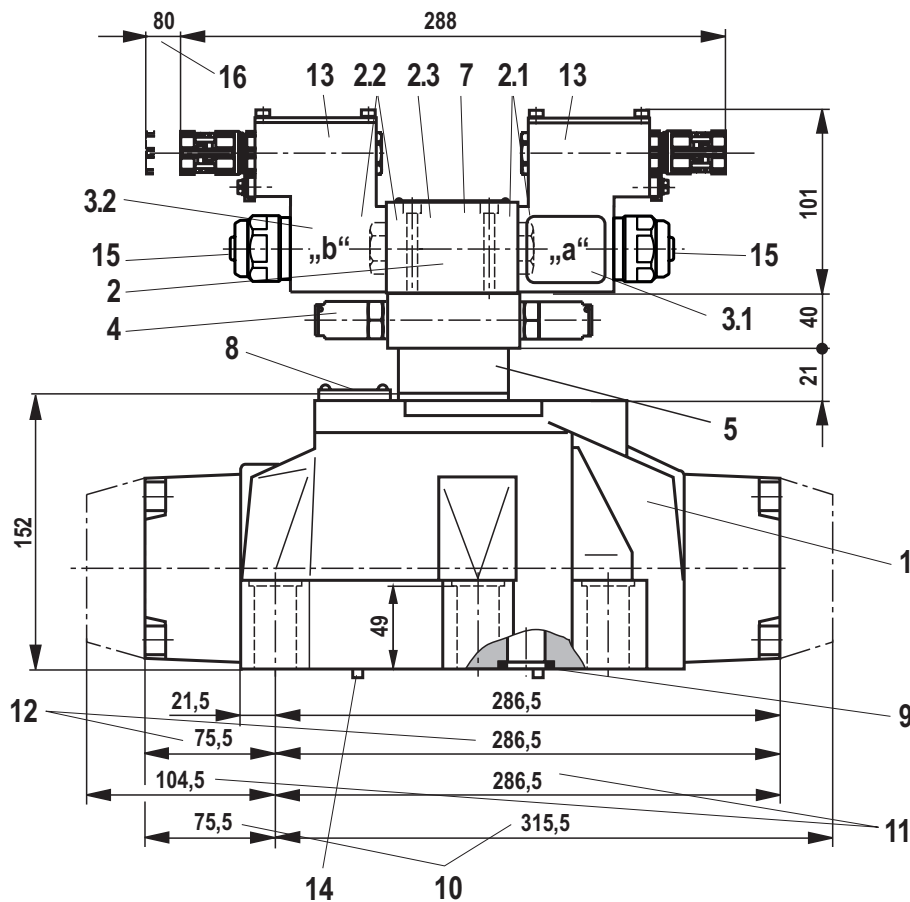

Required surface quality of the valve contact surface

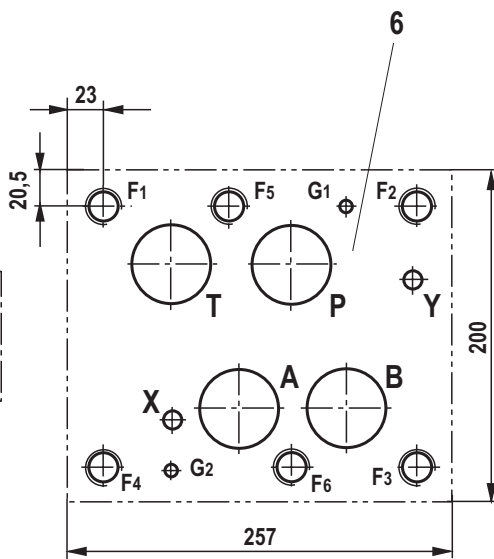
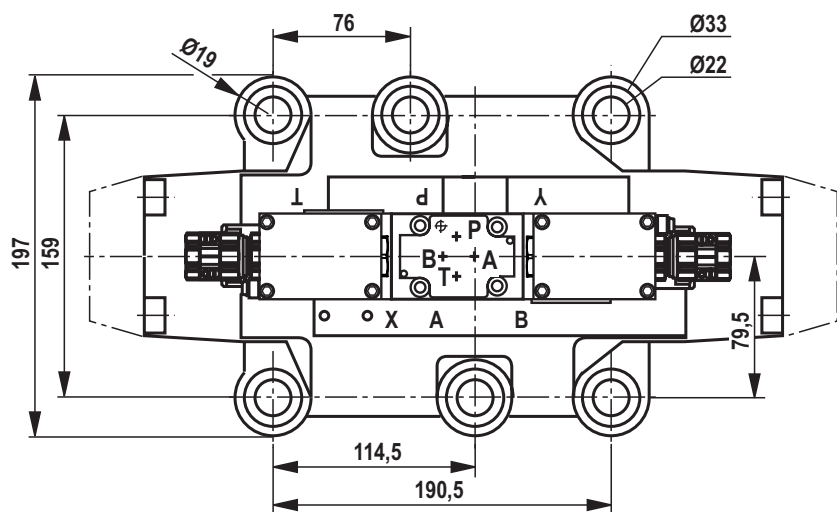

Subplates (separate order) with porting pattern according to ISO 4401-10-09-0-05, see data sheet 45100.

Notice:

Subplates are no components in the sense of directive 2014/34/EU and can be used after the manufacturer of the overall system has conducted an assessment of the risk of ignition. The "G...J3" versions are free from aluminum and/or magnesium and galvanized.

Valve mounting screws (separate order)

For reasons of stability, exclusively use the following valve mounting screws:

6 hexagon socket head cap screws
ISO 4762-M20x80-10.9-fIZn-240h-L
 (friction coefficient $\mu_{total} = 0.09$ to 0.14)

Item explanations see page 25.

Dimensions

- | | |
|--|---|
| <ul style="list-style-type: none"> 1 Main valve 2 Pilot control valve type 4WE 6...XE according to data sheet 23178-XE 2.1 • Pilot control valve type 4WE 6 D... (1 solenoid "a") for main valves with symbol C, D, K, Z
symbol HC, HD, HK, HZ • Pilot control valve type 4WE 6 JA... (1 solenoid "a") for main valves with symbol EA, FA, etc., spring return 2.2 • Pilot control valve type 4WE 6 Y... (1 solenoid "b") for main valves with symbol Y
symbol HY • Pilot control valve type 4WE 6 JB... (1 solenoid "b") for main valves with symbol EB, FB, etc., spring return 2.3 • Pilot control valve type 4WE 6J... (2 solenoids) for main valves with 3 spool positions, spring-centered 3.1 Valve solenoid "a" 3.2 Valve solenoid "b" 4 Switching time adjustment, optional 5 Pressure reducing valve, optional | <ul style="list-style-type: none"> 6 Machined valve contact surface
Porting pattern according to:
ISO 4401-05-05-0-05 for NG10
ISO 4401-07-07-0-05 for NG16
ISO 4401-08-08-0-05 for NG25
ISO 4401-10-09-0-05 for NG32 7 Name plate for the pilot control valve 8 Name plate for the complete valve 9 R-rings/O-rings 10 2-spool position valves with spring end position in the main valve (C, D, K, Z) 11 2-spool position valves with spring end position in the main valve (Y) 12 3-spool position valves, spring-centered
2-spool position valves with hydraulic end position in the main valve 13 Terminal box 14 Locking pin 15 Manual override, optional 16 Space required to remove the solenoid coil |
|--|---|